



Smith Meter® AccuLoad® IV

Bulletin SS06200 Issue/Rev. 0.0 (4/17)





Electronic Preset Delivery System

The Smith Meter AccuLoad IV family of presets provides safe and reliable control as well as accurate measurement for custody transfer loading and unloading of petroleum liquid products. With several models to choose from there's one that's right for any application whether part of a complex system involving automation, blending and numerous load arms or a small scale bulk plant. The AccuLoad product line has been continuously refined for over 35 years to provide the ultimate in features and flexibility. AccuLoad IV is tailored for current operations and adaptable to future growth and enhancements.

Applications

Applications include batch loading of biofuels, gasoline, antifreeze, lube oils, fuel oils, solvents, LPG, NGL and chemicals. The system is ideal for truck, barge, or rail car loading at loading racks, bulk plants, shipping docks, processing installations and tank farms where straight products, as well as blended products, must be accurately loaded.

Models

ST	QT
<ul style="list-style-type: none"> » Explosion-proof enclosure » Two-arm operation » Up to 4 single or dual pulse product meter inputs » Up to 4 additive meter inputs » Up to 24 additive meter inputs with A4I I/O option » AccuLoad III to IV Upgrade Kit (UG3) 	<ul style="list-style-type: none"> » Explosion-proof enclosure » Up to six-arm operation » Up to 6 single or dual pulse product meter inputs » Up to 4 additive meter inputs » Up to 24 additive meter inputs with A4I I/O option » AccuLoad III to IV Upgrade Kit (UG3) 
N4	SA
<ul style="list-style-type: none"> » NEMA 4x enclosure » One or two-arm operation » Up to 4 single or dual pulse product meter inputs » Up to 4 additive meter inputs with local I/O » Up to 24 additive meter inputs with remote A4I I/O » Stainless steel enclosure » Integral card reader, indicator lights and "stop" button options  <p style="font-size: small;">* Optional switch and lights not shown.</p>	<ul style="list-style-type: none"> » NEMA 4x enclosures » Up to eighteen-arm operation » Up to 24 single or dual pulse product meter inputs » Up to 56 additive meter inputs with A4I option » Up to 96 additive meter inputs with remote A4I option » Integral card reader, indicator lights and "stop" button options on the MMI » AccuLoad III to IV Upgrade Kit (FMU)  <p style="font-size: small;">* Optional switch and lights not shown.</p>

AccuLoad IV-SA

The Smith Meter AccuLoad IV Split Architecture System is a unique solution for multiple arm, multiple meter control and measurement systems used to control a lane of loading arms. The system is designed to mount in either a North American Class I Div. 2 area, a Class I Zone 2 area or a General Purpose area. Up to 18 loading arms and 24 meters can be controlled and monitored by the system, which includes the Man Machine Interface (MMI) and the Flow Control Module (FCM). The MMI provides the display and user interface for the system, while the FCM houses the control and I/O for the loading arms. These loading arms can be controlled either as blended or straight product arms. The system has the flexibility of handling multiple blending applications, straight ratio blending, side stream blending, and up to six-product sequential blending on the same loading lane. Using a single MMI, up to six arms can be loaded simultaneously. Using two MMIs, up to twelve arms can be loaded simultaneously.

AccuLoad III to IV Upgrade Kit (UG3)

The Smith Meter AccuLoad III to IV Upgrade Kit is designed to upgrade an AccuLoad III to AccuLoad IV. This upgrade kit allows customers who have purchased AccuLoad IIIs to upgrade their entire unit technology with minimal down time and reduced installation or automation costs. The upgrade kit maintains the loading arm configuration being used in the AccuLoad III. The upgrade uses the AccuLoad III housing while replacing existing cover boards and software.* The upgrade kit gives AccuLoad III owners the opportunity to protect their operation and take advantage of the leading edge features of AccuLoad IV without having to change their existing terminal automation or conduit system.

* SA Upgrade requires new MMI and replacing existing boards and software in the FCM.

AccuLoad IV Features

- » Individually configurable load arm functions for:
 - Straight product delivery
 - Sequential blending
 - Ratio blending
 - Hybrid blending
 - Vapor recovery operation
 - Unloading operation
- » Up to six products for each load arm
- » Simultaneous operation of all load arms
- » User-configurable inputs and outputs
- » Additive control for metered, smart, piston injectors
- » Digital or analog valve flow control
- » Single and dual channel meter pulse inputs
- » Fully configurable flow profile
- » Alarm monitoring with configurable action
- » Standalone operation or remote control through communication link
- » Measurement profile
 - Automatic temperature and pressure compensation and density correction
 - API tables for light products to crude oils
 - Biofuel volumetric compensation
 - Meter factor linearization
- » Extensive security
 - Five levels of passcodes
 - Per parameter access control
 - Audit log of parameter changes
- » Onboard diagnostics
 - View detailed operational status
 - Manual control of inputs/outputs
 - Event logging
 - Communication monitoring
 - Valve solenoid maintenance monitoring
 - Valve tuning assistance
- » Ethernet and serial communications
 - Modbus
 - Network printing
 - Proximity card reader
 - Driver access database
 - Promass interface
 - Configurable BOL
- » Browser based remote access
 - Control/monitoring of loading process
 - Diagnostic information
 - Virtual loading screen anywhere on the network
- » Built-in Virtual Load Rack (VLR) simulates load rack equipment for diagnostics and training
- » Boolean/algebraic processing
- » Automatic flow control with recovery
- » Linux operating system, built for networking
- » Alphanumeric color user interface display

Programmable Inputs / Outputs

AccuLoad IV-ST and AccuLoad IV-QT

The Smith Meter AccuLoad IV-ST and AccuLoad IV-QT are explosion-proof designs with integral 8.4" color touch screen.

AccuLoad IV-ST, ST-UG3, and N4 Hardware

Digital Inputs	AC	DC	Total
Standard	5	6	11
Optional A4I	5	16	21
Digital Outputs	AC	DC	Total
Standard	11	3	14
Optional (One A4I)	31	3	34
Analog Inputs/Outputs – Up to 6			

AccuLoad IV-QT and QT-UG3 Hardware

Digital Inputs	AC	DC	Total
Standard	9	14 ¹	23
Optional (One A4I)	9	24	33
Optional (Two A4Is)	9	34	43
Digital Outputs	AC	DC	Total
Standard	27	11 ¹	38
Optional (One A4I)	47	11	58
Optional (Two A4Is)	67	11	78
Analog Inputs/Outputs – Up to 6			

AccuLoad IV-SA

The AccuLoad IV Split Architecture System is flexible in that the FCM module can be supplied with one to four board sets.

AccuLoad IV-SA Hardware

Digital Inputs Per Board Set			Total			
Description	AC	DC	1 Board Set	2 Board Sets	3 Board Sets	4 Board Sets
Standard	9	142	23	46	69	92
Optional A4I	9	242	33	66	99	122
Digital Outputs Per Board Set						
Description	AC	DC	1 Board Set	2 Board Sets	3 Board Sets	4 Board Sets
Standard	27	11	38	76	114	152
Optional A4I	47	11	58	116	174	232
Analog Inputs/Outputs – Up to 6						

Load Arm Features

The AccuLoad loading arm functions are individually programmable providing flexibility for how each arm can be configured. The AccuLoad IV-ST, N4 and UG3 hardware supports up to four product meters that can be distributed among two load arms while the AccuLoad IV-QT hardware allows six product meters that can be distributed among six load arms. The AccuLoad SA system has the capacity for up to twenty four product meters that can be distributed over 18 load arms.

AccuLoad IV has the flexibility of handling loads arm functions that include straight product, sequential blending, straight ratio blending, side stream ratio blending, wild stream blending and hybrid blending. Other arm functions include unloading and vapor recovery operation.

Straight Product

A straight arm is used to deliver a single product through a single meter.

Sequential Blending

Blending of multiple products into a compartment through the sequencing of product specific block valves, one product at a time, through one meter and control valve and flowing through a single loading arm into a compartment.

¹ Eight of the DC I/O points are individually programmable as either inputs or outputs; the number indicated is the maximum if all programmed as inputs or all programmed as outputs.

Ratio Blending

Blending multiple products simultaneously through dedicated product lines each having its own meter and control valve, co-mingling in a common header and flowing through a single loading arm into a compartment.

Side Stream Blending

Blending of a minor product and a major product where the minor product is metered and controlled by a valve and the main product is free flowing. A second meter and control valve is located downstream of the blending point and measures/controls the flow of the blended product. This is sometimes referred to as inline blending.

Hybrid Blending

Hybrid blending is defined as a combination of sequential blending and ratio blending. A typical hybrid blending arm configuration may be three sequential products and one or two ratio products. The sequential products flow one at a time and in most cases one of the ratio products would flow simultaneously with each of the sequential products. The ratio product(s) can be plumbed either upstream or downstream of the sequential product meter. On a hybrid arm there must be at least one sequential product configured.

Wild Stream Blending

This blending configuration is used in applications where it is desired to continuously blend two products where a preset volume is not normally used. One of the products can be uncontrolled (wild stream). This option is available with the hybrid arm configuration. Wild Stream Blending supports spontaneous blend percent changes and also for changing meters to accommodate varying flow rates.

Unloading

The AccuLoad IV allows a vessel to be unloaded without entering a preset volume. Implementing this feature requires that a load arm be identified as “unloading”.

Vapor Recovery – “Straight with VRS”

This arm type supports delivering a single product while monitoring the amount of vapor recovered. This feature requires a load arm type to be programmed as “Straight with VRS”. Two meters are required for this application to determine the amount of vapor recovered while loading light density products. The AccuLoad provides a vapor product total and a net mass total between the liquid product meter and the vapor product meter in the system. This feature will allow for the AccuLoad to monitor the amount of vapor leaving a loading compartment while measuring and controlling the amount of product entering the same loading compartment. The product entering the compartment can be delivered in volume or mass. The vapor leaving the compartment must be measured in mass and requires the vapor recovery meter to be a mass meter.

Standard Features

Temperature Compensation

The temperature compensation option provides the customer with the capability of compensating for the variance in temperature from a reference temperature. This option is used with an RTD input or a temperature transducer and, excluding the accuracy of the fluid temperature measurement, will exactly match the proper volume correction factor of ASTM-D-1250-04 and API MPMS CH 11.1-2004 over the fluid temperature range of -58°F to 302°F (-50°C to 150°C). The following selections for API standard compensation methods can be programmed: API 2004 crude oils, API 2004 refined Products, API C Tables - special products API 2004 lube oils, API E Tables - LPG, NGL, API Chapter 11.2.1M, API Chapter 11.2.2M, API 1952 Tables 6, 23, 24, 53 & 54 (supported for Asphalt), NH3 - Ammonia, TP-15 vapor pressure calculations conform to API 11.2.5, Aromatic Hydrocarbon products (ASTM D1555).

For light products such as NGL and LPG (E tables), calculations are performed per API Chapter 11.2.4 or GPA Technical Publication TP-27. The standard provides CTLs (correction for temperature on a liquid) calculated to 5 decimal digits (e.g. 0.xxxxx or 1.xxxxx).

For ethanol compensation, selections are available to use API 11.3.3, EPA RFS2, Brazilian tables BR1A, BR1P, and BR2P, and PTB Eth/Gas equations.

Pressure Compensation

The pressure compensation option provides the customer with the capability of compensating the volume of product delivered at varying pressures per API Tables 11.1, 11.2.1 and 11.2.2, using a 4-20 mA pressure transducer input per preset position. This option also contains real-time control functions for maintaining system pressures at the meter to a minimally-acceptable, user-definable level (pressure transducer not included). This option is particularly useful for light products, such as LPG, where the compressibility factor varies a great deal with different pressures.

Density Correction

The density correction option provides the customer with the capability of correcting the volume of product delivered at varying densities. This can be either a frequency input or a 4-20 mA input.

Metered Injectors, Piston Injectors, and Smart Additives

The AccuLoad IV has been designed to provide maximum flexibility when it comes to additive control. The unit is capable of handling metered injectors, piston injectors and smart additives simultaneously.

The AccuLoad is capable of controlling four additive injector metered systems. (See Hardware Options for additional injector systems.) The AccuLoad controls the additive solenoids to precisely inject the additive into the main product. It monitors the pulses of the additive meter and controls the amount of the additive, based on the incoming pulses from the additive meter and the main product meter.

Additive monitoring and smart additives provide the capability for the AccuLoad to monitor the feedback from the piston injectors of the additive products. The AccuLoad monitors the injector feedback switches for a change of state and counts the errors and alarms if no change is detected within the cycle or a period of time, depending on how the unit is programmed. The AccuLoad will totalize the additive volume based on confirmation signals and a programmable volume per cycle. The totalized volume will print on the emulated load ticket printed on the shared printer output.

For Smart additives, the firmware has also been designed with a Master/Slave type of communications, with the AccuLoad being the master and the Additive Injector System being the slave. The AccuLoad constantly interrogates the Additive Injector System for a change in status. The AccuLoad can be operated with communications control over the Smart Additive Injector System or with communication/pulse control. When the AccuLoad has communication control over the Additive System, it will constantly monitor the Additive System for its status, poll the additive totals, and signal the system when to inject the additive all through the communications line.

The AccuLoad communications package has also been designed with a pass-through communications mode. In this mode of operation the supervisory computer can talk to the Additive Injector System through the communication lines that have been run to the AccuLoad and from the AccuLoad to the Additive Injector System(s).

Dual Pulse Security

The AccuLoad may be configured to provide continuous monitoring, error indication alarm, and correction of the pulse transmission for each preset position* as per API Petroleum Measurement Standard, Chapter 5.5, Level A, and Institute of Petroleum Standard, IP 252/76, Part XIII, Section 1, Level A, or ISO 6551:1982. In order to utilize this feature, a transmitter capable of providing the proper pulse signal must be connected to the pulse inputs of the AccuLoad such as the Smith Meter® UPT. The UPT transmitter provides four signals: "A," "A inverted," "B," and "B inverted." The "A" and "B" signals are 90 electrical degrees out-of-phase and used for dual-pulse security. The "A" and "A inverted," and "B" and "B inverted" signals are 180 electrical degrees out-of-phase and are used for transmitter power sensing. If power sensing is not required, only "A" and "B" are required for dual-pulse security.

* **Note:** The use of the "A inverted" and "B inverted" signal inputs reduces the amount of available individual meter inputs.

Automated Proving Mode

The AccuLoad IV provides an automated proving mode of operation. When the automated proving mode is activated the AccuLoad will calculate the meter factor for a proving run based on information that is obtained during the prove. The operator can select the flow rate and meter factor that is being proved through the user interface of the AccuLoad. After the prove is complete the operator enters the prover volume and prover temperature and the AccuLoad will calculate the new meter factor and the operator has the choice of downloading it to the program or to ignore it. The AccuLoad also has the capability of providing an average meter factor over a maximum of six proves. This feature allows the operator to prove the meter on all four products, and four meter factors and associated flow rates for each product without having to enter the program mode for each product and meter factor.

Boolean and Algebraic Processing

The AccuLoad IV provides the customer the flexibility to set-up inputs and outputs for tasks that are not standard in the unit. Through Boolean processing, relays can be turned on and off through equations and events set-up by the customer. For example, a relay is required to close at the first trip point of the load. This can be set-up using Boolean processing and does not require special software from TechnipFMC.

Algebraic processing is also an area that the customer can use to do simple mathematical calculations that are not in the unit. These calculations can then be used on the configurable reports for the current batch being run by the unit.

Hardware Options

AccuLoad Interface module

The AccuLoad IV Interface module (A4I) provides additional flexibility to the AccuLoads standard features. The optional A4I module provides either ten additional metered additive injector systems or twenty additional programmable outputs. This module provides the AccuLoad IV with the capability of handling up to fourteen metered injectors, fourteen meter inputs, fourteen solenoid valve outputs, and fourteen additive pump outputs. Adding two A4I modules provides the capability to handle up to twenty-four additive injector systems (meters, additive pumps, and solenoid valves) or an additional forty programmable AC outputs. The optional A4I module(s) are designed to either be mounted in the AccuLoad IV housing or in a stand-alone enclosure (REM). One of the four communication ports is required to communicate with the A4I modules.

Card Reader Interface

The AccuLoad IV can obtain proximity card data through a proprietary interface board. The AccuLoad can also pass card data and status to a host computer. The card reader interface is activated by choosing the card reader option in the serial communications function program code. This new interface offers the potential for enhanced functionality and security ranging from simple transaction-stamping with driver card data to a mini automation system with validation and authorization.

Man Machine Interface (MMI) for SA units

The Division 2 approved Man Machine Interface (MMI) may be ordered with optional green and red indicator lights, and/or a "stop" button. These are user-wired devices. The indicator lights can be used in place of the indicator lights on the overflow/ground system. The MMI can also be ordered with a proximity card reader. (Refer to Specification Sheet SS06044 for card reader details.)

Fuse Holders for SA units

Up to 50 fuse holders can be mounted in the Division 2 enclosure. These fuse holders can be used as additional protection for wiring to valve solenoids, etc.

Specifications

Accuracy

Calculated Accuracy: The gross at standard temperature to gross volume ratio, excluding the accuracy of fluid temperature measurement, will exactly match the proper volume correction factor of ASTM-D-1250-04 over the fluid temperature range of -58°F to 302°F (-50°C to 150°C).

Temperature Measurement Accuracy: Fluid temperature is measured to within $\pm 0.72^\circ\text{F}$ ($\pm 0.4^\circ\text{C}$) over the fluid temperature range of -328°F to 572°F (-200°C to 300°C). Fluid temperature is measured to within $\pm 0.45^\circ\text{F}$ ($\pm 0.25^\circ\text{C}$) over the fluid temperature range of 32°F to 572°F (0°C to 300°C).

Stability: 0.1°F (0.06°C)/year.

Flow Totalizing: Within one pulse of input frequency.

Electrical Inputs (Per board set on SA)

AC Instrument Power:

Universal input 100 to 240 VAC, 58W maximum, 48 to 63 Hz. The AC circuitry is fuse-protected.

Surge Current: 28A maximum for less than 0.1 seconds.

Power Interruption Tolerance: Interruption of power greater than .05 seconds (typical) will cause an orderly shut-down of the AccuLoad and the control valve will be signaled to close.

Note: A constant voltage transformer (CVT) is recommended if the available AC power is suspected not to comply with these specifications.

Pulse Input:

Type: High-speed, edge-triggered, optically isolated pulse transmitter input. The input pulse must rise above V (high min.) for a period of time and then fall below V (low) to be recognized as a pulse by AccuLoad IV.

V (High): 5 VDC minimum to 28 VDC maximum. V (Low): 1 VDC maximum.

Input Impedance: 1.6 K Ω .

Pulse Resolution: 1 pulse/unit minimum, 9,999 pulses unit maximum.

Frequency Range: 0 to 10.0 kHz.

Response: Within one pulse to a step change in flow rate.

Mode: Single, dual, dual with power sensing, density. Duty Cycle: 35/65 to 65/35 (on/off).

Temperature Probe:

Type: four-wire, 100 Ω Platinum Resistance Temperature Detector (PRTD).

Temperature Coefficient: @ 32°F: 0.00214 $\Omega/\Omega/^\circ\text{F}$ (0.00385 $\Omega/\Omega/^\circ\text{C}$)

Temperature Range: -148°F to 572°F (-100°C to 300°C)

Offset: Temperature probe offset is program-adjustable through the AccuLoad user interface in ± 0.1 degree increments in the unit of temperature measurement used.

Self Calibrating: Lead length compensation that requires no resistance balancing of leads.

Analog (4-20 mA):

Type: Two-wire, 4-20 mA current loop receiver, isolated from ground, programmable as to function.

Span Adjustment: Program-adjustable through the AccuLoad user interface or communication in tenths of the unit used.

Input Burden: 50 Ω . Accuracy: $\pm 0.025\%$ of range when Calibration factors are programmed.

Resolution: One part in 65,536. Voltage Drop: 2 Volts maximum.

Sampling Rate: One sample/300 mSec minimum.

Analog (1-5 Vdc):

Type: Two-wire, 1-5 VDC voltage loop receiver, isolated from ground, programmable as to function.

Span Adjustment: Program-adjustable through the AccuLoad user interface or communications in tenths of the unit used.

Input Burden: 1 m Ω

Accuracy: $\pm 0.025\%$ of range when Calibration factors are programmed.

Resolution: One part in 65,536.

Sampling Rate: One sample/300 mSec minimum.

AC Inputs:

Type: Optically-isolated, solid-state voltage sensor.

Input Voltage Range: 90 to 280 VAC.

Pickup Voltage: 90 VAC minimum.

Drop-out Voltage: 30 VAC maximum.

Current at Maximum Voltage: 20 mA maximum.

Input Resistance: 44,000 Ω typical.

DC Inputs:

Type: Optically-isolated solid state voltage sensors.

Input Voltage Range: 5 to 28 VDC.

Pickup Voltage: 5 VDC minimum.

Drop-out Voltage: Less than 1 volt.

Current at Maximum Voltage: 15 mA maximum.

Input Level Duration: 120 mSec minimum.

Electrical Outputs (Per board set on SA)**DC external power for ancillary equipment:**

24 Vdc \pm 10%, 1 A maximum, short circuit protected.

AC Outputs:

Type: Optically-isolated, AC, solid-state relays. User-programmable as to function.

Load Voltage Range: 90 to 280 VAC (rms), 48 to 63 Hz.

Steady-State Load Current Range: 0.025A (rms) minimum to 1.0A (rms) maximum into an inductive load.

Leakage Current at Maximum Voltage Rating: 0.1 mA (rms) maximum @ 240 VAC.

On-State Voltage Drop: 1.5 Vac at maximum load.

DC Outputs:

Type: Optically-isolated solid state output. User-programmable as to function.

Switch Blocking Voltage: 30 VDC maximum.

Load Current: 150 mA maximum with 0.6 volt drop.

Analog (4-20 mA):

Type: Two-wire, 4-20 mA current loop transmitter, isolated from ground, programmable as to function.

Span Adjustment: Program adjustable through the AccuLoad user interface or through communications.

Accuracy: \pm 0.10% of range when Calibration factors are programmed.

Resolution: One part in 65,536.

Voltage Burden: 4 volts maximum.

Analog (1-5 Vdc):

Type: Two-wire, 1-5 VDC voltage loop transmitter, isolated from ground, programmable as to function.

Span Adjustment: Program adjustable through the AccuLoad user interface or through communications.

Accuracy: \pm 0.10% of range when Calibration factors are programmed.

Resolution: One part in 65,536.

Pulse Output 1 & 2:

Type: Optically-isolated solid state output. Pulse output units are program-selectable through the AccuLoad user interface or communications.

Switch Blocking Voltage (Switch Off): 30 VDC maximum.

Load Current (Switch On): 10 mA with 0.6 volts drop. Frequency Range: 8 to 2,500 Hz.

Duty Cycle: 50/50 (on/off).

Pulse Output 3, 4 & 5:

Type: Solid state relay digital output switch Load Current: 110 mA max.

Frequency Range: 0-125 Hz Duty Cycle: 50/50 (on/off)

Programmable maximum frequency output: All intended pulses will be eventually transmitted, the total period may increase to ensure all pulses are output.

Note: *When used, these outputs use the DC output points on the A4M (DC output 1-3 respectively).*

Prover Pulse Output 1 & 2:

High Speed Prover Output (Open Collector Opto Coupler)

Type: Optically-isolated solid state output

Switch Blocking Voltage (Switch Off): 30 VDC maximum.

Load Current (Switch On): 10 mA with 0.6 volts drop.

Frequency Range: 0 to 3000 Hz.

Duty Cycle: Duty cycle will mirror the meter's output duty cycle.

Display/User Interface:

Integral alphanumeric/graphic, 8.4 inch 800x600, 24 bit color screen with a resistive touchscreen, with Day/Night mode.

Communications (Per board set on SA)

General

Number of Ports: Four, plus Ethernet port.

(1) EIA-232, (1) EIA-485, (2) programmable for EIA-232 or EIA-485,

Configuration: Multi-drop network. Up to 32 AccuLoad IVs can be connected onto the same transmit and receive data lines, via serial communications. Standard IT practices should be followed when connecting multiple AccuLoad IVs via an Ethernet hub, router, or switch.

Data Rate: User interface-selectable to asynchronous data rates of 1,200, 2,400, 4,800, 9,600, 19,200, 38,400, 57,600 or 115,200 bps (serial comm).

Data Format: Programmable one start bit, programmable seven or eight data bits – even, odd, or no parity, one stop bit.

Line Protocol: Half-duplex, full-duplex, no character echo.

Data Structure: ASCII character-oriented, modeled after ISO Standard 1155.

Protocol: Smith Meter Terminal mode, Smith Meter Minicomputer mode, Modicon Modbus (PI-MBUS-300 Rev. D). Smith Meter and Modbus protocol over TCP/IP.

AccuLoad III Style: Terminal Mode, Minicomputer Mode.

EIA-232

Type: Interfaceable with EIA-232 data communication standards. Data transmitters are tri-state design.

Typical Applications: Product receipt ticket printing (used with a stand-alone ASCII printer or as a backup in the standby mode with automation for BOL emulation) or communications with Product Management Automation Systems. Up to 16 AccuLoads can be connected onto the same transmit and receive data lines.

EIA-485

Type: Interfacable with EIA-485 data communication standards.

Typical Application: Communications with Product Management Automation Systems, additive injection systems.

Number of Units per Communication Line: Up to 32 AccuLoads can be connected onto the same transmit and receive data lines.

Ethernet: 10/100 Base RJ-45

EIA-568, Cat 5 or greater

Ethernet Connectivity Features

- ARP/RARP and DHCP support
- PING echo diagnostics
- Smith Meter protocol and Modbus protocol support over TCP/IP
- HTTP server functionality
- Dynamic name server lookups (DNS client)
- Simple Mail Transport Protocol (SMTP)
- Post Office Protocol V3 (POP 3)
- Support for network printers (LPR client)
- Compliance with TCP/IP standards
- Remote access using most browsers
- Web browser requirement for remote access:
 - Google Chrome: 44+
 - Internet Explorer: 10+
 - Firefox: 42+

Specifications: AccuLoad N4 and MMI Only

Red and Green Indicating Light Units – (Optional)

Electrical Ratings Bulbs: LED Lamp, 120 VAC or 240 VAC in Red or Green

Terminals: Saddle clamp type for one or two copper conductors 22-12 AWG (0.34 - 4.0 mm²), tighten to 7 Lb-in (0.8 Nm)

Stop Button – (Optional)

Electrical Ratings Contact Block:

NEMA Contact Rating Designator A600 (AC)

Make and Emergency Interrupting Capacity (Amps): 60 (120V); 30 (240V)

Normal Load Break (Amps): 6 (120V); 3 (240V)

Thermal Current (Amp): 10

VoltAmperes: Maximum Make 7200; Maximum Break 720

Contact Type: 1NO-1NC (Momentary) Color: Black

Button Color: Black

Terminals: Stainless steel saddle clamp type for 1 x 18 - 14 AWG (0.75 - 2.5 sq. mm) solid or stranded copper conductor, tighten to 9 Lb-in (1 Nm)

Card Reader – (Optional)

The Smith Meter Card Reader can be added to the face of the AccuLoad IV-N4 or MMI. This option provides an integrally mounted RF-based proximity reader to the AccuLoad IV. It is capable of interpreting multiple card formats and transmitting card data either to the AccuLoad IV or directly to an automation system. Refer to Bulletin [SS06044](#) for further information.

Electrical Inputs

DC Instrument Power: 24 Vdc, 35 mA; 12 Vdc, 70 mA

Electrical Outputs

DC Output:

Type: Optically-isolated solid state output.

Switch Blocking Voltage: 30 Vdc maximum

Load Current: 150 mA maximum with 0.9 volt drop (6 Ω typical)

Card Interface (Optional)

Excite Frequency: 125 kHz

Typical Read Range: Within up to 2" (5.08 cm)

MMI Only

Power Supply (Optional)

The optional power supply can be used for DC instrument power for the MMI versus using power from the A4M in the FCM.

AC-to-DC Power Supply

Input: 115/240 VAC Nominal, 47-63Hz

Output: 24V, 50/60W

VDSL Ethernet Extenders (Optional)

For Upgrade from AccuLoad III to AccuLoad IV-FMU, if the existing EIA-232 serial communication cable from the MMI to the FCM is to be used, Ethernet Extender modules are required in the FCM and MMI.

For new installations, if the wiring distance between the MMI and FCM is over 100 meters (328'), the Ethernet Extender modules are required in the FCM and MMI.

IEX-402-VDSL2

Up to 100 Mbps over twisted-pair copper wires

One 10/100BaseT(X) and one DSL port

Data rates of up to 100 Mbps with transmission distance of up to 3 km

Electrical Safety Approvals

ALIIV-ST and ALIV-QT Enclosure

Class I, Division 1, Groups C & D; UNL-UL Enclosure 4X, CNL-CSA Enclosure 4

Class I, Zone 1, Group IIB, Class I, Zone 1, AEx d ia IIB T6 Gb, IP65 Tamb = -40°C to +55°C*

UL File E23545

** Temperature ratings for the enclosure is limited to +55°C ambient for UL listed devices that are meant to be touched by an operator during normal operations*

DEMKO 15 ATEX 1462X; IEC Ex UL 15.0016X

Ex d ia IIB T6 Gb IP 65 Tamb = -40°C to +60°C.

Upgrade Kit UG3

Classified by Underwriters laboratories Inc. for use with Listed AccuLoad III.

UL File E204189

For use with DEMKO 02 ATEX 130951X or IECEx UL 11.0018X Certificate

ALIV-N4, ALIV-MMI and ALIV-FCM Enclosure

Industrial type 4X stainless steel.

Class I, Division 2, Groups C & D; Class I, Zone 2, Group IIB T4

Tamb = -40°C to +50°C, UNL-UL ENCL. 4X, CNL-CSA ENCL.4,

UL File E23545.

Note: *The AccuLoad IV does not contain intrinsically-safe protected circuitry for field connections; therefore, all peripheral equipment must be suitable for the area in which it is installed.*

Weights & Measures Certifications

United States NTEP Certificate of Conformance issued by the National Conference on Weights & Measures COC #99-141

Canadian Notice of Approval, issued by Measurement Canada (Pending)

The following reports have been issued by NMI (Netherlands Measurement Institute)*:

- » Evaluation Certificate TC8664
- » OIML R117-1 & R117-2 Test Report
- » Welmec 7.2 Software Evaluation Test Report

Australian National Measurement Institute*

EU MID (Measuring Instrument Directive)*

MID Certificate Issued by PTB (National Metrology Institute of Germany) (Pending)

Please consult the factory for other approvals.

Electromagnetic Compatibility

EMC directive 2014/30/EU.

EN 61326-1: Electrical equipment for measurement, control and laboratory use

Environment

Ambient Operating Temperature: -40°F to 140°F (-40°C to 60°C).

Humidity: 5 to 95% with condensation.

Note: *Housing material is aluminum alloy; severe salt environments are highly corrosive and protection and/or maintenance is required for such locations.*

***Note:** Only models with ATEX and IECEx certifications.

Modeling Code¹ – ALIV-ST and ALIV-QT

ALIV	QT	XP	ARM1	A00000	1
Hardware Model Designation					Hardware Option
ALIV - ST					0 - None
ALIV - QT					1 - A4I Board
					2 - (2) A4I Boards*
Housing					Analog Modules²
XP - Explosion-Proof Housing					DIGIT 1 - # of RTDs
UG3 - Upgrade Kit for AccuLoad III					DIGIT 2 - # of 4-20 mA inputs
					DIGIT 3 - # of 4-20 mA outputs
					DIGIT 4 - # of 1-5 VDC inputs
					DIGIT 5 - # of 1-5 VDC outputs
					Firmware
			MMI		ARM4 - Four-arm operation*
			ARM1 - One-arm operation		ARM5 - Five-arm operation*
			ARM2 - Two-arm operation		ARM6 - Six-arm operation*
			ARM3 - Three-arm operation*		
					PEMEX Non-resettable Volumes Option
			ARP1 - One-arm operation		ARP4 - Four-arm operation*
			ARP2 - Two-arm operation		ARP5 - Five-arm operation*
			ARP3 - Three-arm operation*		ARP6 - Six-arm operation*

¹ A complete model number is required when ordering the AccuLoad IV.

² Maximum of 6 Analog Modules. For Upgrade Kits, existing Analog Modules in the AccuLoad III can be re-used in the AccuLoad IV UG3.

*Note: Not available with ALIV-ST Hardware

Modeling Code¹ – ALIV-N4

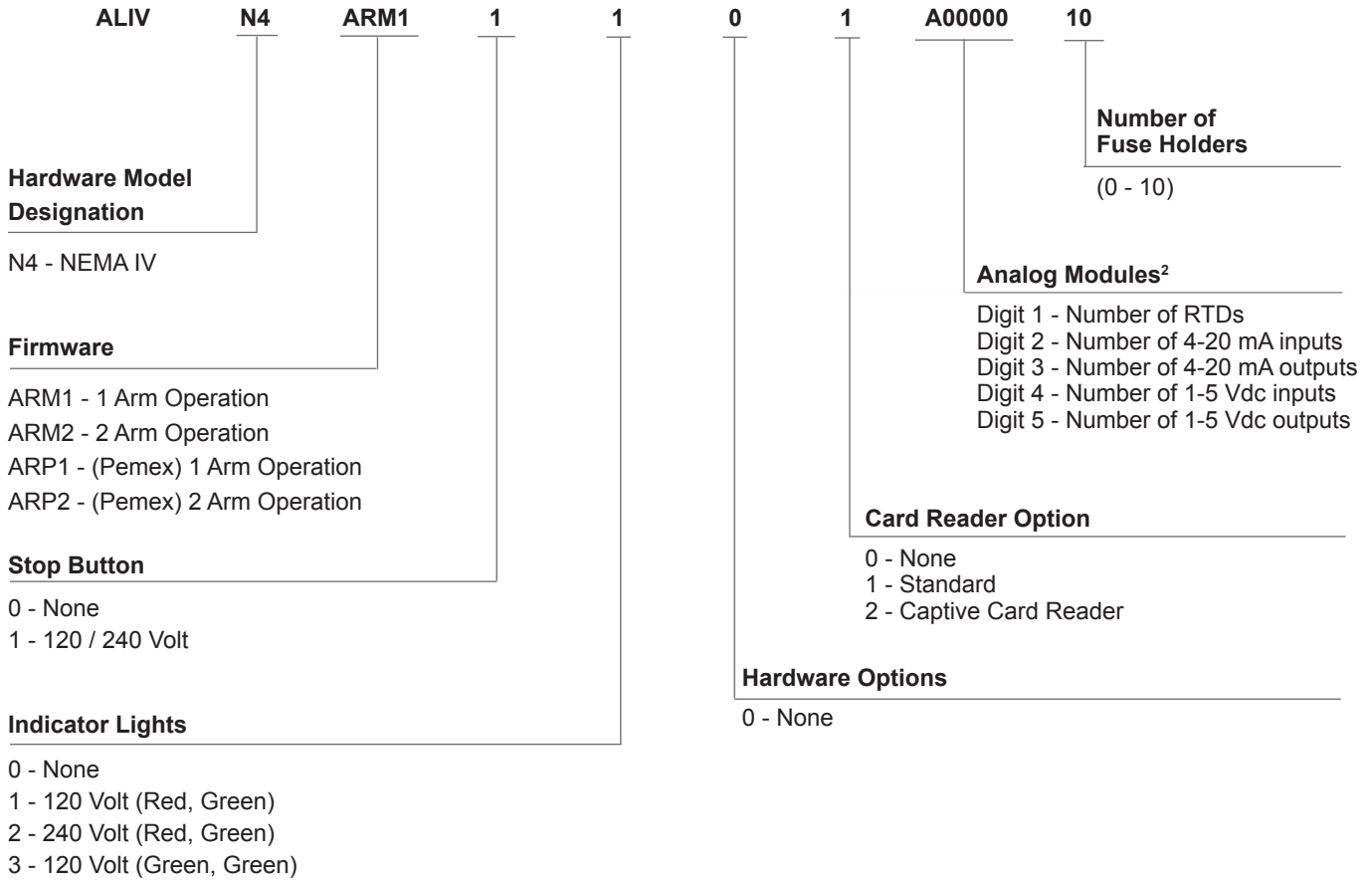

¹ A complete model number is required when ordering the AccuLoad IV.

² Maximum of 6 Analog Modules. For Upgrade Kits, existing Analog Modules in the AccuLoad III can be re-used in the AccuLoad IV UG3.

Modeling Code¹ – ALIV – Split Architecture MMI

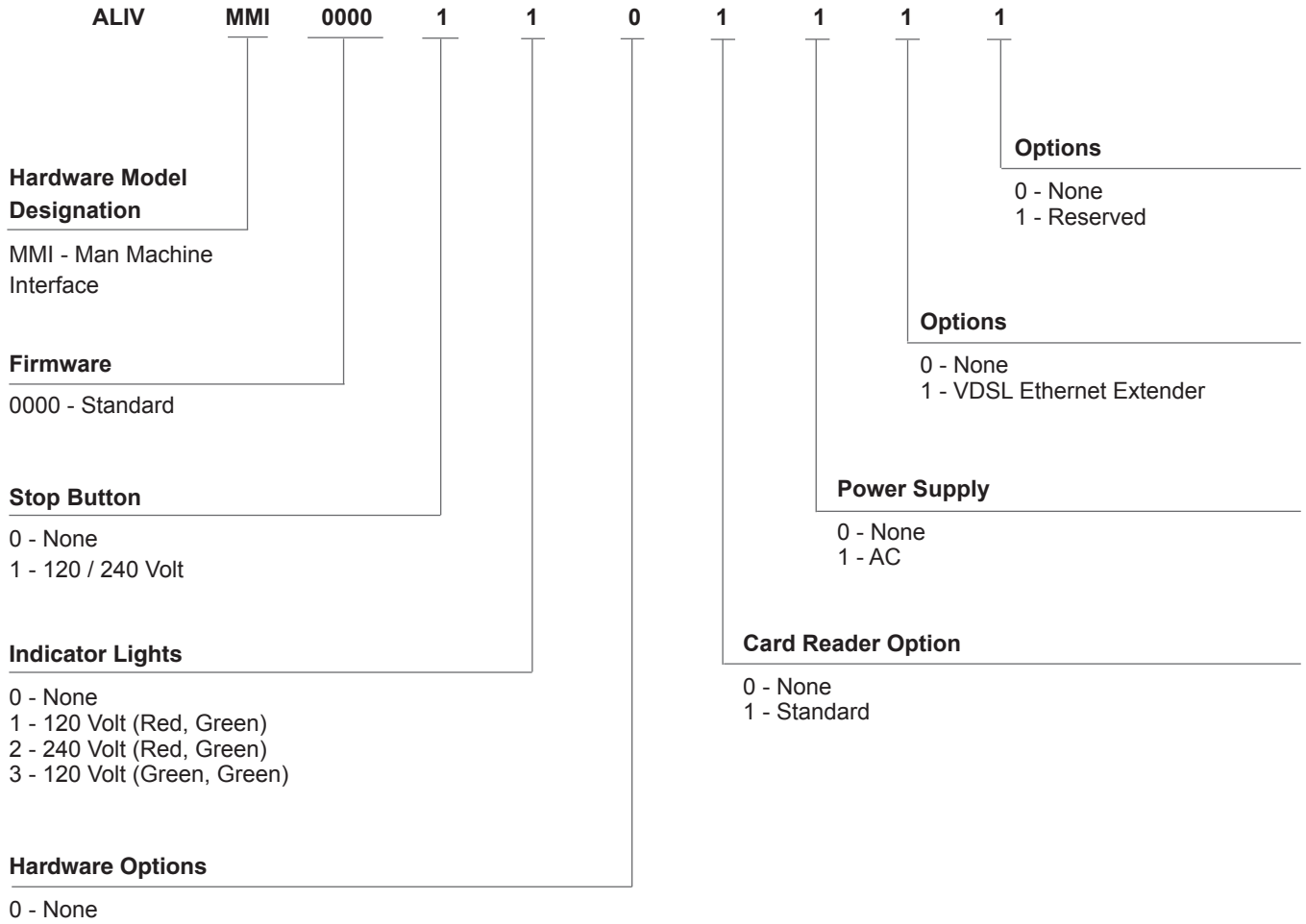

¹ A complete model number is required when ordering the AccuLoad IV.

Modeling Code¹ – ALIV – FCM

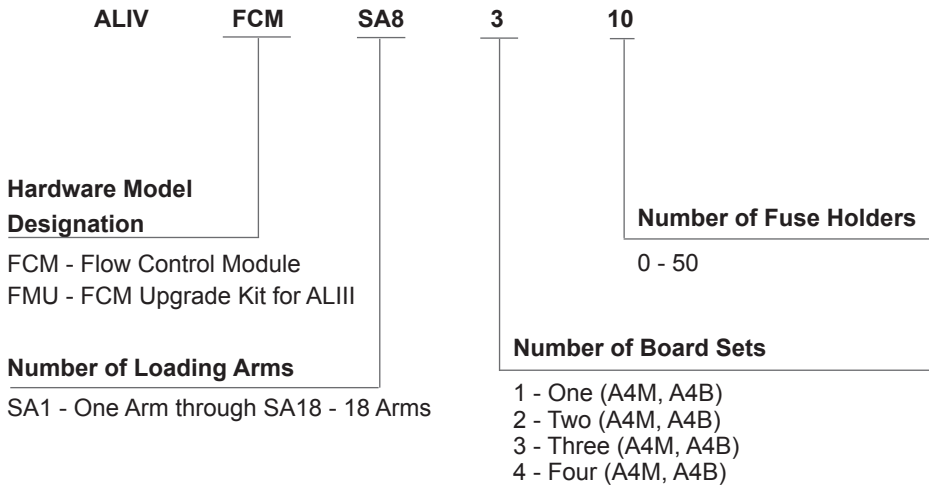

Modeling Code¹ – ALIV – Board Set Modeling

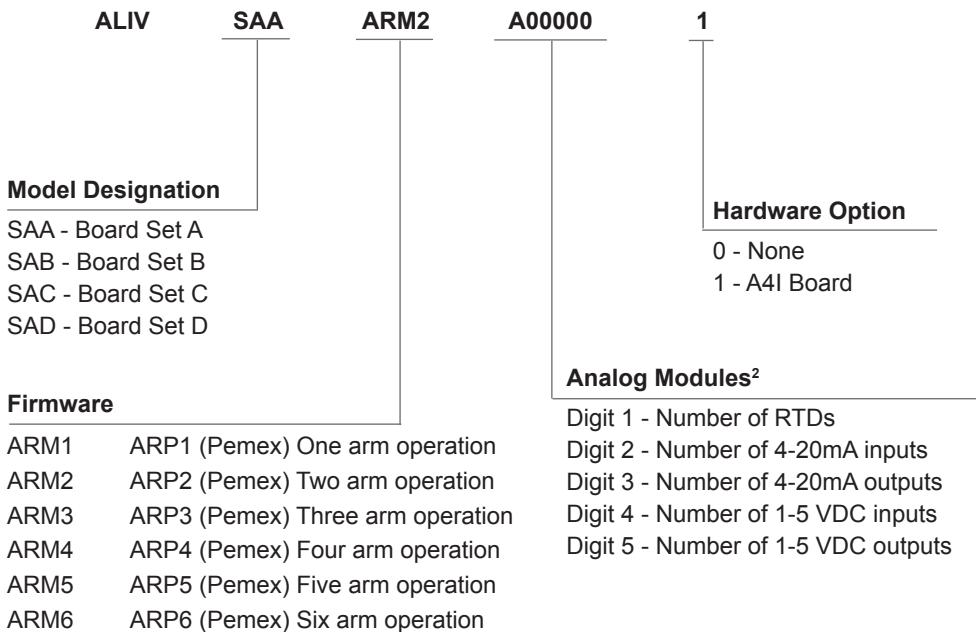

¹ A complete model number is required when ordering the AccuLoad IV.

² Maximum of 6 Analog Modules. For Upgrade Kits, existing Analog Modules in the AccuLoad III can be re-used in the AccuLoad IV FMU.

Dimensions – ALIV-QT

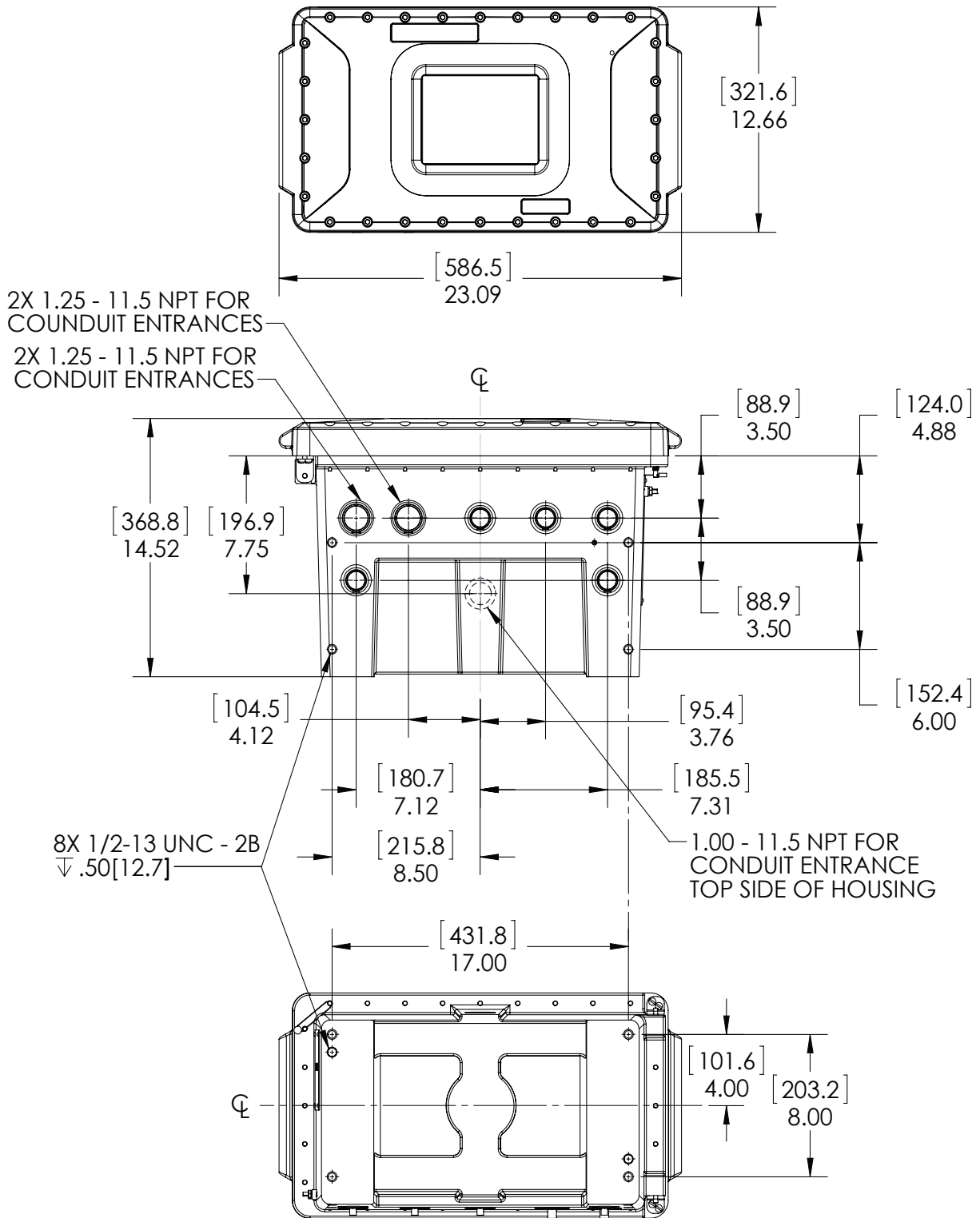

Note: Dimensions – Inches to the nearest tenth (millimetres to the nearest whole mm), each independently dimensioned from respective engineering drawings.

Figure 1. Explosion-Proof Housing – ALIV-QT Hardware. ALIV-QT Weight – 125 lb (57.5 kg).

Dimensions – ALIV-ST

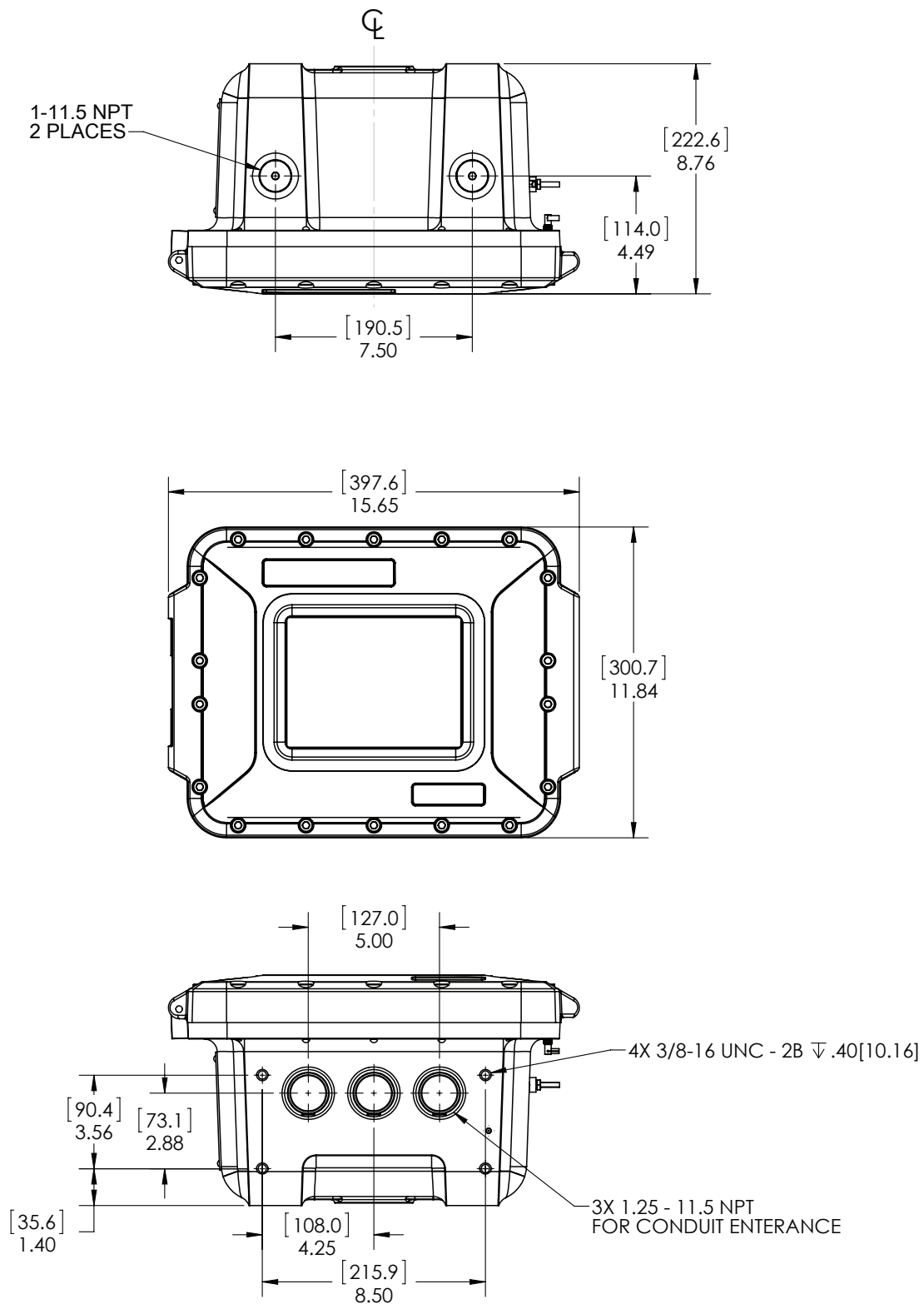

Note: Dimensions – Inches to the nearest tenth (millimetres to the nearest whole mm), each independently dimensioned from respective engineering drawings.

Figure 2. Explosion-Proof Housing – ALIV-ST Hardware. ALIV-ST Weight – 50 lb (22.7 kg).

Dimensions – ALIV-N4 and MMI

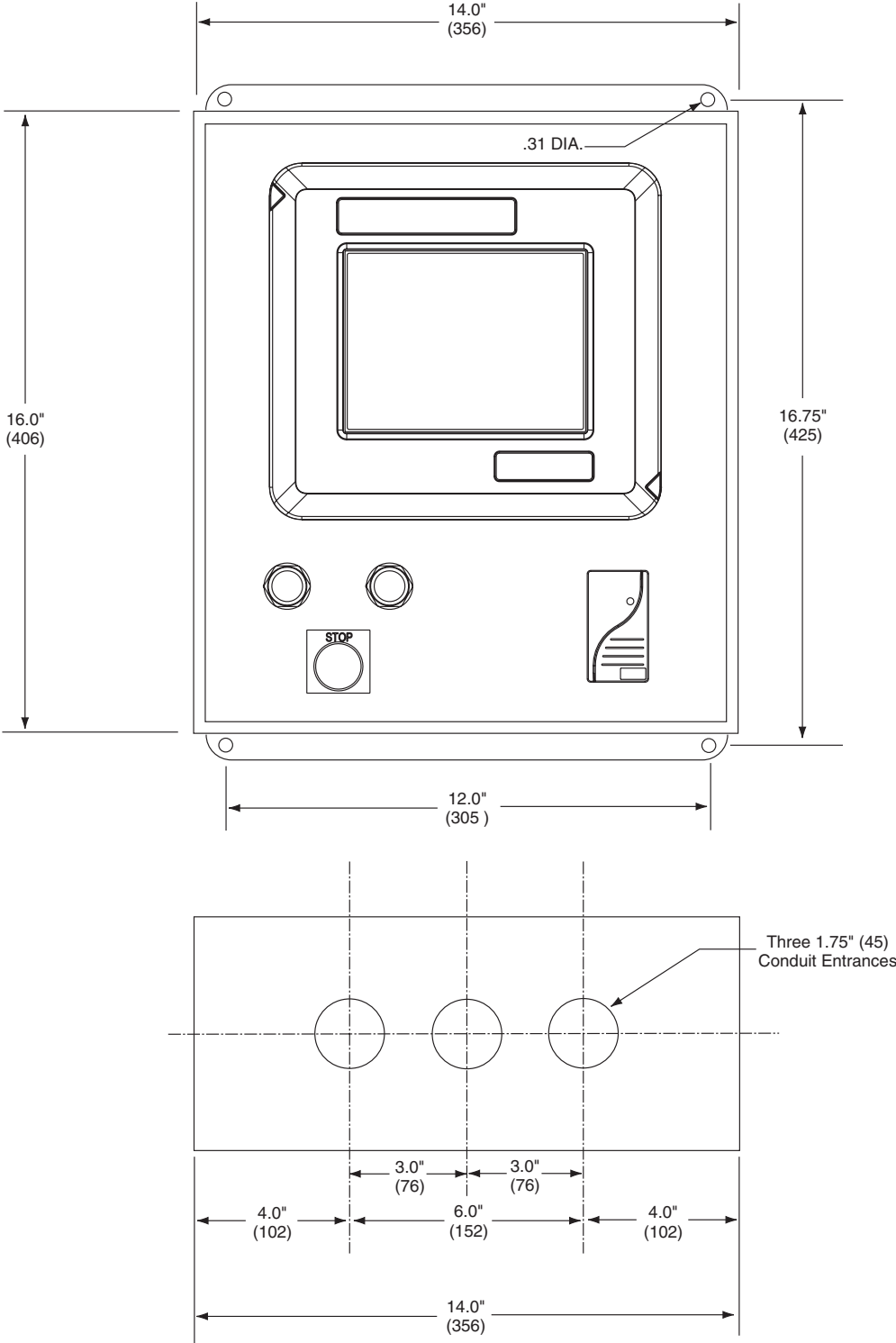

Note: Dimensions – Inches to the nearest tenth (millimetres to the nearest whole mm), each independently dimensioned from respective engineering drawings.

Figure 3. ALIV-N4 and MMI. Weight – 35 lb (15.9 kg).

Dimensions – ALIV-FCM

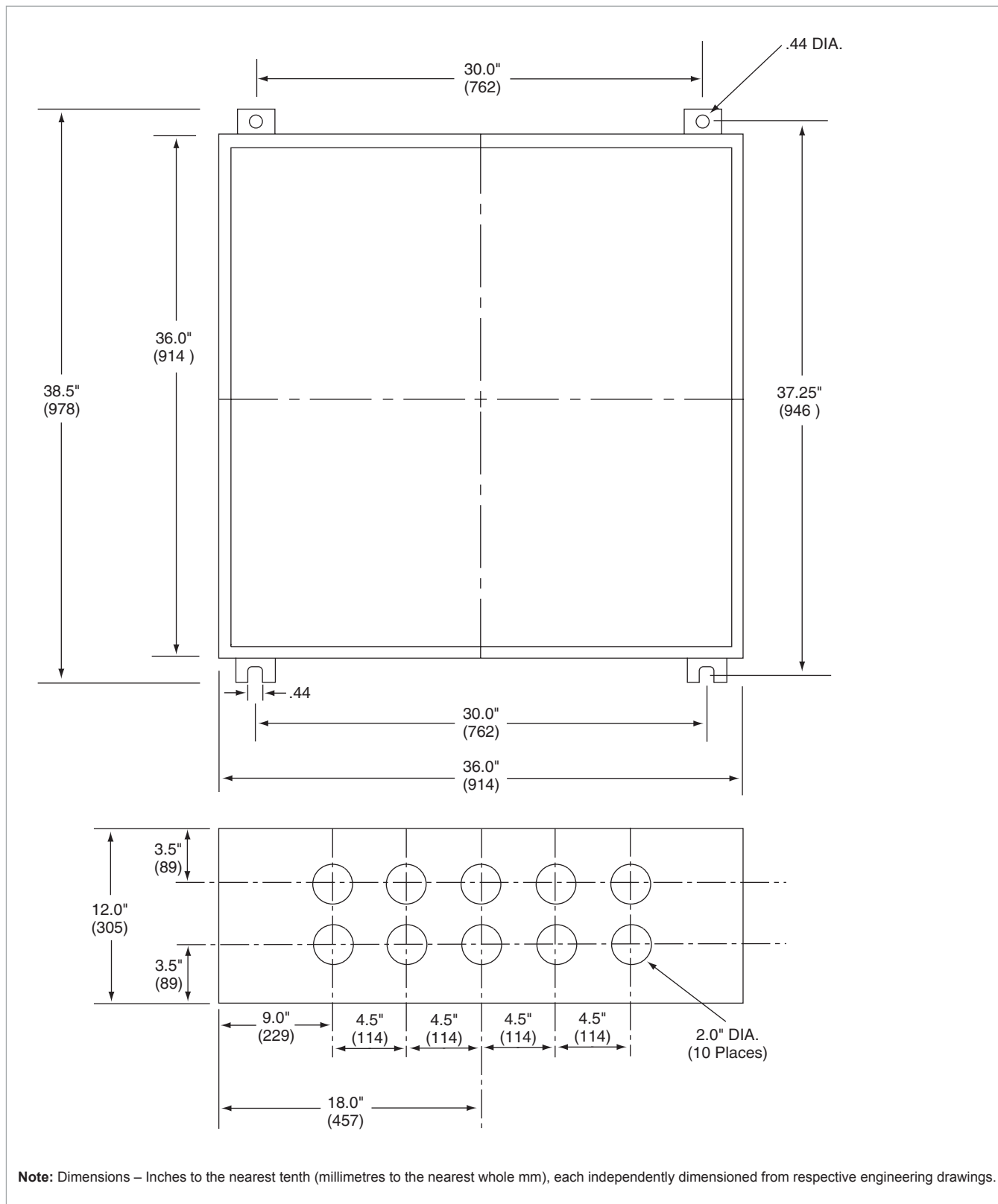

Figure 4. Flow Control Unit (FCM) Dimensional. ALIV-FCM Weight – 120 lb (54.54 kg).

REM For Remotely Mounted A4I Modules

Specifications (A4I Module)

Electrical Inputs

DC Instrument Power: 24 VDC \pm 10%, 1 watt maximum

Pulse Input:

Type: High-speed, edge-triggered, optically isolated, compatible with contact closure, open collector or voltage sink/source pulse transmitter input. The input pulse must rise above V (high min.) for a period of time and then fall below V (low) to be recognized as a pulse.

V (High): 10 VDC minimum to 24 Vdc maximum. V (Low): 8 VDC maximum.

Pulse Resolution: 1 pulse/unit minimum, 9,999 pulses/ unit maximum.

Frequency Range: 0 to 5 kHz.

Response: Within one pulse to a step change in flow rate.

Minimum Pulse Width: 50 μ S.

Electrical Outputs

AC Outputs:

Type: Optically-isolated, AC, solid-state relays. User-programmable by the host as to function.

Load Voltage Range: 90 to 280 VAC (rms), 48 to 63 Hz.

Steady-State Load Current Range: 0.025A (rms) minimum to 0.5A (rms) maximum into an inductive load.

Leakage Current at Maximum Voltage Rating: 0.1mA (rms) maximum at 240 VAC.

On-State Voltage Drop: 1.5 Vac at maximum load.

Environment

Ambient Operating Temperature: -40°F to 140°F (-40°C to 60°C).

Humidity: 5 to 95% with condensation.

Remote Enclosure: Explosion-proof (NEMA 7, Class I, Groups C and D) and watertight (NEMA 4X), IP65

Approvals

UL/CUL:

Class I, Division 1, Groups C and D; Class II, Groups E, F and G, UNL-UL Enclosure 4X, CNL-CSA Enclosure 4
Class I, Zone 1, AEx d IIB T6, IP65

UL File E23545

ATEX / IEC Ex:

DEMKO 11 ATEX 1103869X IEC Ex UL 11.0029X

Ex d IIB T6 IP65 Tamb = -40°C to +60°C

Modeling Code – ALIV – REM

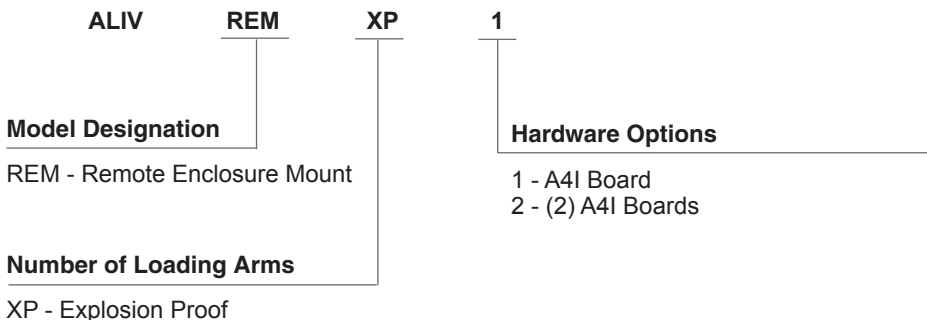

Dimensions – ALIV-REM

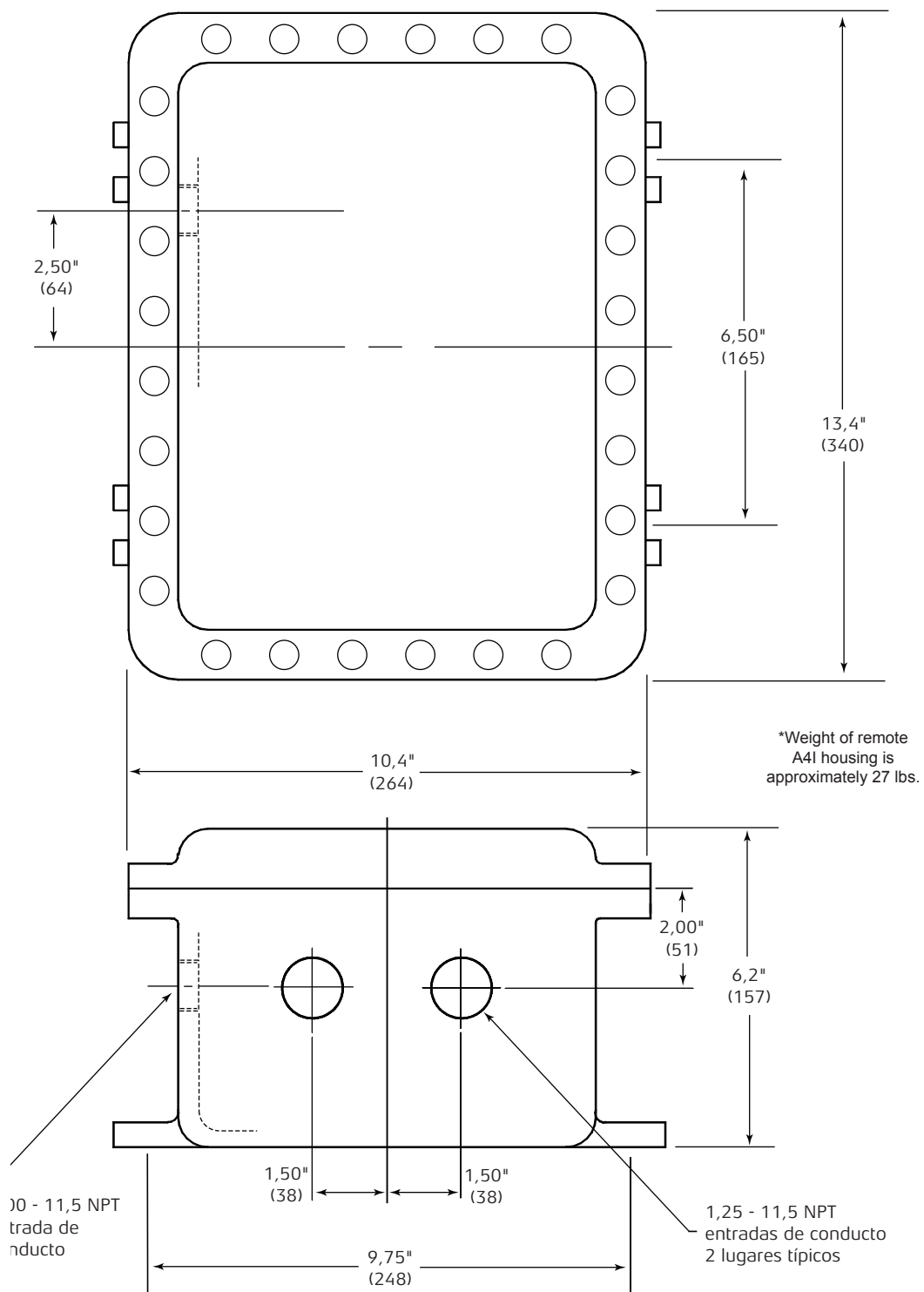

Note: Dimensions – Inches to the nearest tenth (millimetres to the nearest whole mm), each independently dimensioned from respective engineering drawings.

Figure 5. Remote Housing (Optional A4I). ALIV-REM Weight – 27 lb (12.25 kg).

Trading Partner:



We Build Trust

HOUSTON, TX - USA
+ 1 281.469.1423

info@ferrumenergy.com

ferrumenergy.com



The specifications contained herein are subject to change without notice and any user of said specifications should verify from the manufacturer that the specifications are currently in effect. Otherwise, the manufacturer assumes no responsibility for the use of specifications which may have been changed and are no longer in effect. Contact information is subject to change. For the most current contact information, visit our website at TechnipFMC.com and click on the "Contact Us" link.

TechnipFMC.com

FMCTechnologies.com/MeasurementSolutions

© TechnipFMC 2017 All rights reserved. SS06200 Issue/Rev. 0.0 (4/17)

TechnipFMC
FMC Technologies
Measurement Solutions, Inc.
500 North Sam Houston Parkway West,
Suite 100
Houston, Texas 77067 USA
P: +1 281.260.2190

USA Operation
1602 Wagner Avenue
Erie, Pennsylvania 16510 USA
P: +1 814.898.5000

Germany Operation
Smith Meter GmbH
Regentstrasse 1
25474 Ellerbek, Germany
P: +49 4101 304.0