

# Model 210 Digital Electro-Hydraulic Set-Stop

Bulletin SS03009 Issue/Rev. 1.1 (10/17)

## Smith Meter® Valves

The Smith Meter Model 210 Valve is typically used in conjunction with either a Smith Meter AccuLoad® or microLoad Preset Controllers for loading and unloading at truck racks, bulk plants or processing installations.

Features
• Simple control loop
• Control loop needle valves for tuning
• Low pressure drop
• Separate opening and closing speed control
• Compound spring
• Horizontal or vertical applications
• Full range of optional control functions
• 2" Reduced Port Valve – Ideal for renewable fuels blending, controlling flow down to 3 GPM.
• Fail to close design

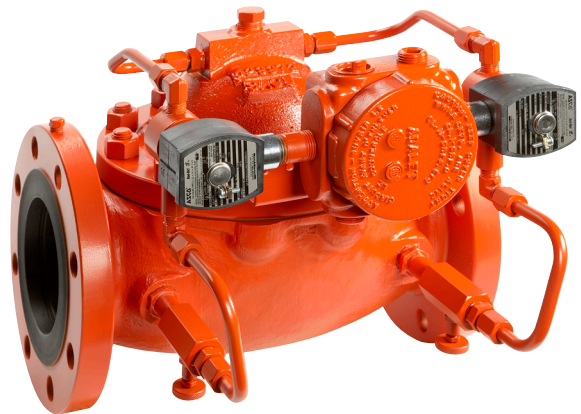

## Operation

The Smith Meter Model 210 Valve is a Smith Meter 200 Series Valve with two solenoid controls (see Figure 1). The normally-open (N.O.) and normally-closed (N.C.) solenoids, located in the upstream and downstream portions of the control loop, respectively, control the operation of the valve. With both solenoids energized, high upstream pressure is blocked allowing the product in the cover to vent to low downstream pressure, opening the main valve. Conversely, de-energizing both solenoids allows high upstream pressure to close the valve.

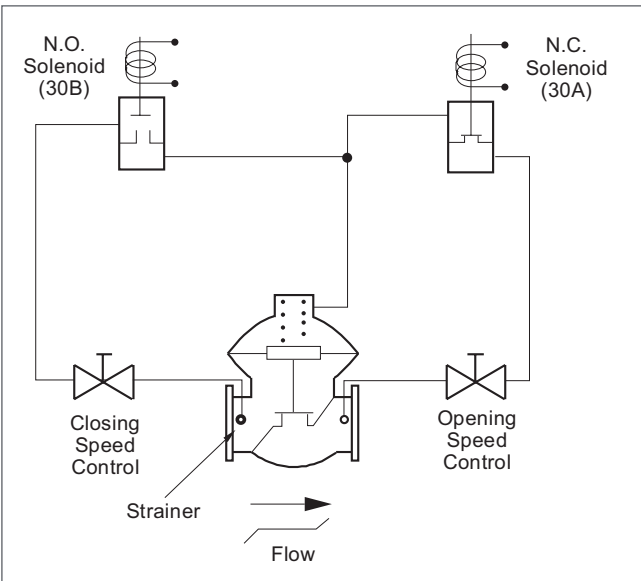

Figure 1. Model 210 Valve Schematic

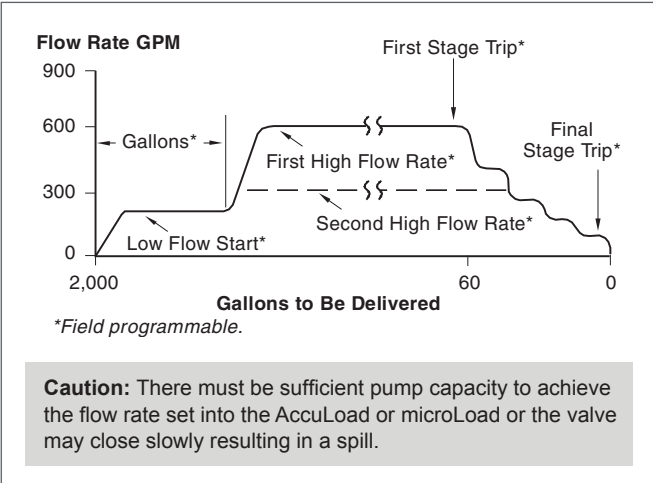

Figure 2. Typical Load Cycle

Energizing just the N.O. solenoids locks fluid in the valve cover, which locks the valve poppet in a fixed position, to maintain a constant flow rate as long as operating conditions do not change. When operating conditions change, causing a change in flow rate for that fixed valve opening, the flow controller signals the appropriate solenoid to open momentarily to readjust flow rate back to its set value. When the set flow rate changes (e.g., from low flow start to high flow limit, or during multi-step valve shutdown), the appropriate solenoid is signalled to open until flow rate adjusts to the new set value. See Figure 2 for a typical truck loading flow rate sequence.

Located between each solenoid and the main valve port is a valve response control device, typically a needle valve. This device is used to fine tune the opening and closing rate of the valve, as well as providing total control loop isolation for ease of service. Adjustment of these devices control the flow to the cover chamber, permitting adjustments based on product viscosities and pressures.

### Reverse Flow and Pressure Relief

Reverse flow through the valve will occur if the pressure downstream of the valve exceeds the pressure upstream of the valve by 2 to 6 psig depending on valve size. This may be desirable to provide pressure relief due to thermal expansion for the piping downstream of the valve, however, proper thermal relief analysis for the system is required. When the pressure downstream of the valve is greater than the pressure upstream of the valve, fluid will flow from the downstream side to the upstream side through the valve seat. The exact pressure at which this will occur is dependent on the size and configuration of the valve, as well as, the specific hydraulic environment in which it's installed.

The 80B/07A is a combination of check valve/pressure relief. This option is available for the 210 series valve and when installed, does not allow reverse flow through the main valve seat but instead provides an adjustable pressure relief valve (07A) which relieves downstream pressure in excess of the setting to the upstream side of the valve through the valve cover.

## Specifications

### Maximum Viscosity

200 SSU (40 mPa•s)<sup>1</sup>; Above 200 SSU, consult factory

### Pressure Rating/Connections<sup>2, 3, 4</sup>

Class 150 ASME, 285 psi (19.6 bar)

Class 300 ASME, 300 psi (20.7 bar)

### Temperature Range

Valve Elastomer	Temperature Range <sup>2, 5</sup>
LS (Low Swell) Buna	-20°F to 200°F (-28°C to 93°C)
Buna-N	-20°F to 200°F (-28°C to 93°C)
Viton	-20°F to 350°F (-28°C to 177°C)

### Voltage (Solenoids)

**Standard:** 120 VAC / 60 Hz or 110 VAC / 50 Hz

**Optional:** 240 VAC / 60 Hz or 220 VAC / 50 Hz  
24 VDC  
12 VDC

### Materials of Construction

	Housing	Internals	Seals
Main Valve	Cast Steel	Stainless Steel, Carbon Steel, Ni-Resist Ductile Iron	Low Swell Buna <sup>7</sup> , Viton-A or Buna-N
Solenoid Valves	Stainless Steel	Stainless Steel	Viton-F <sup>7</sup> , Buna-N, Chemraz
Needle Valves <sup>7</sup>	Steel <sup>9</sup>	Steel <sup>9</sup>	Viton/ PTFE <sup>6</sup>
Tubings and Fittings	Steel <sup>9</sup>	Steel <sup>9</sup>	–
Ball Valves <sup>8</sup>	Steel <sup>9</sup>	Chrome Plated Steel Ball/Steel Body	PTFE <sup>6</sup>

### Weight

Size	lb.
2"	46
3"	83
4"	136
6"	260

1 1 mPa•s = 1 cP.

2 Pressure ratings are based on temperatures of -20°F to 100°F (-28°C to 38°C). For operation at higher temperatures, the maximum working pressure may be derated.

3 PED requirements limit applications to liquids with maximum vapor pressures of .5 bar above atmospheric pressure, at maximum allowable temperature.

4 PED required for all European countries. Equipment must be manufactured by our Ellerbek, Germany facility.

5 For temperature outside these ranges, consult factory.

6 Polytetrafluoroethylene (PTFE).

7 Standard.

8 Optional (for 4" and 6" only)

9 Stainless steel ball valves and/or tubing and fittings available

## Pressure Drop

(When valve is not flow-limiting or wide open)

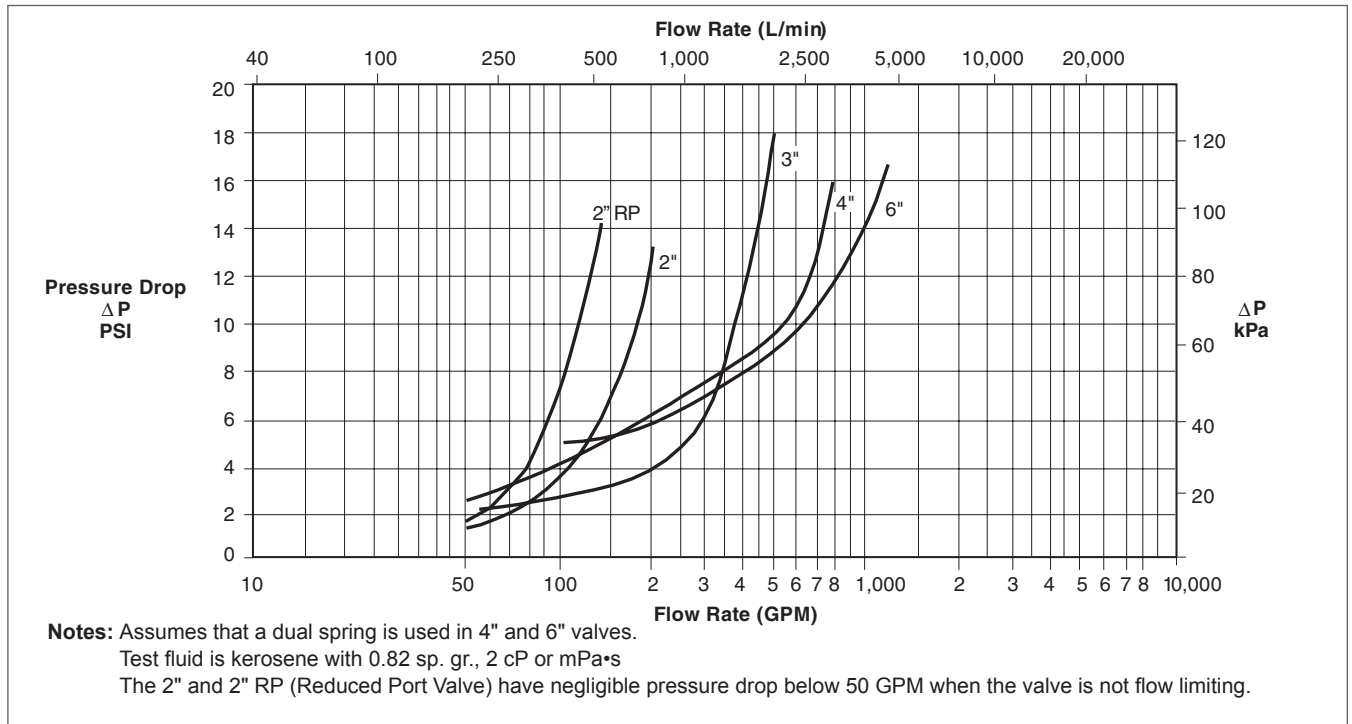

## Dimensions

Inches (mm)

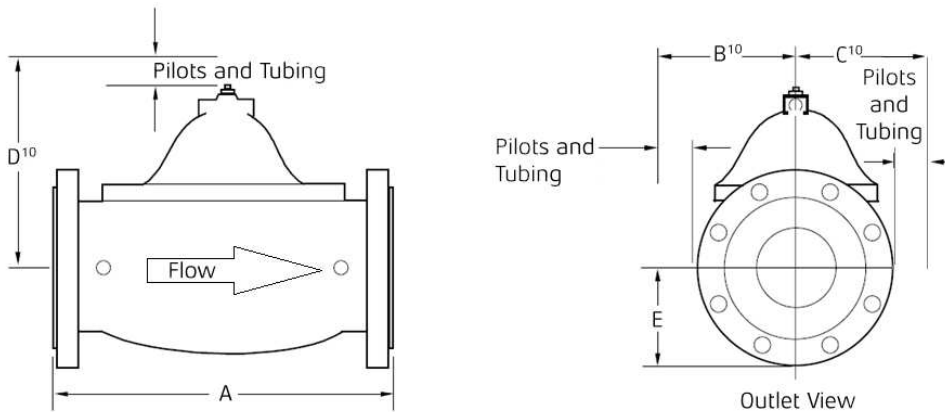

Size	A Class 150	A Class 300	B10	C	D11	E Class 150	E Class 300
2" and 2" RP	8.0 (203)	8.5 (216)	8.0 (203)	4.0 (102)	7.5 (140)	3.0 (76)	3.3 (84)
3"	11.0 (279)	11.8 (300)	9.5 (241)	4.0 (102)	9.5 (241)	3.8 (97)	4.1 (104)
4"	13.5 (343)	14.1 (358)	9.5 (241)	4.9 (124)	9.5 (241)	4.5 (114)	5.0 (127)
6"	17.0 (432)	17.9 (455)	11.0 (279)	6.6 (168)	12.5 (318)	5.5 (140)	6.3 (160)

**Note:** Dimensions – Inches to the nearest tenth (millimeters to the nearest whole mm), each independently dimensioned from respective engineering drawings.

10 Minimum, normal, maximum

11 Pilots and tubing will be within dimensions

**Trading Partner / Aliado Comercial:**

HOUSTON, TX - USA + 1 281.469.1423  
info@ferrumenergy.com

**ferrumenergy.com**



**FERRUM  
ENERGY**

We Build Trust

*Generamos Confianza*

**Revisions included in SS03009 Issue/Rev. 1.1 (10/17):**

Page 2: Reverse flow and pressure relief information added.

The specifications contained herein are subject to change without notice and any user of said specifications should verify from the manufacturer that the specifications are currently in effect. Otherwise, the manufacturer assumes no responsibility for the use of specifications which may have been changed and are no longer in effect.

Contact information is subject to change. For the most current contact information, visit our website at [TechnipFMC.com](http://TechnipFMC.com) and click on the "Contact Us" link.

**TechnipFMC.com**

**FMCTechnologies.com/MeasurementSolutions**

© TechnipFMC 2017 SS03009 Issue/Rev. 1.1 (10/17)

TechnipFMC  
FMC Technologies  
Measurement Solutions, Inc.  
500 North Sam Houston Parkway West,  
Suite 100  
Houston, Texas 77067 USA  
P:+1 281.260.2190

USA Operation  
1602 Wagner Avenue  
Erie, Pennsylvania 16510 USA  
P:+1 814.898.5000

Germany Operation  
Smith Meter GmbH  
Regentstrasse 1  
25474 Ellerbek, Germany  
P:+49 4101.304.0